



WHEEL LOADERS

721E - 721EXT - 821E



	721E	721EXT	821E
Engine Horsepower	137 kW/183 hp	137 kW/183 hp	159 kW/213 hp
Operating weight (max.)	14 500 kg	14 650 kg	17 166 kg
Bucket capacity	2.40 - 2.70 m ³	2.40 - 2.70 m ³	2.80 - 3.30 m ³

EXTRA CONTROL

Torque sensing autoshift transmission with integrated shuttle switch offers directional control. Auto return to work feature and optional Ride Control system reduce operator fatigue and lower cycle times, boosting productivity.

Operator comfort. High production.

ENVIRONMENT FOR OPERATORS

Longer and wider cab offers improved interior space, additional legroom and one of the lowest noise levels in the industry. Easy to reach switch layout and single servo lever for major controls reduce operator fatigue and improve productivity. Optional ride control and air conditioning further boost operator performance.

Total comfort. Maximum productivity.

EFFECTIVE DESIGN

Mid-mounted cooling module located for improved weight distribution. Engine acts as counterweight to reduce overall weight.

Efficient distribution. Solid stability.



ESSENTIAL COMPONENTS

Mid-mounted cooling module ensures constant temperature for increased component life.

Automatic reversible fan keeps radiator cores clean, reducing downtime.

Working well. Working productively.

EXCEPTIONAL ACCESS

One piece electric lift canopy allows easy access to all engine components for service and regular maintenance. Daily checks can be carried out from ground level and the machines have remote fluid drains to ensure no contamination of the ground. **Environmentally friendly. Maximised uptime.**

EXCELLENT VISIBILITY

Reduced engine canopy height improves rearward visibility, while full height glass offers improved view of attachments and front wheels. Engine pre-cleaner mounted in line with exhaust stack to further improve view to the rear. **Easy operation. Improved safety.**



ECONOMY AND PERFORMANCE

Case 667TA/EED common rail electronically-controlled engine offers a choice of three power levels to maximise efficiency. Working modes match engine and hydraulic power to the application, while auto idle function cuts noise and reduces fuel consumption. **High power. Low consumption.**

ENGINE



The 721E and 821E are powered by a Tier III Case 667TA/EED diesel. This electronically-controlled 6.7 litre engine provides a choice of three power and torque ratings, designed to perfectly match the requirements of the machine in any application, maximising fuel economy.

There are four Working Modes, controlled by the operator from a console in the cab. Standard is for use in normal operating, offering the engine's rated output with maximum hydraulic power and flow. Max Power provides a 5.5 per cent power boost in the 721E, and an 11 per cent net power gain for the 821E. This mode is intended for extreme operating conditions.

For lighter duties, there is Economy, which drops the engine revs and power output, reducing fuel consumption and noise further. The final operating mode is Auto Power; which matches the engine's power curve to the digging application. Electronic control also allows for three engine idle settings, increasing engine efficiency and reducing fuel consumption.

FRONT VISIBILITY



The 721E and 821E benefit from an ergonomically designed cab that is far larger than on the D series machines. The pillarless floor-to-ceiling glazing to the front and sides of the machine offers an unparalleled view of the bucket or attachment.

The operator has a clear view of the front wheels, aiding manoeuvrability and making the machine easier to place accurately in a stock handling or loading operation. This reduces cycle times and increases productivity.

Redesigned front fenders ensure that the glass stays clear in even the worst ground conditions, while powerful windscreen wipers keep the main window clear in all weathers.

The central control console is compact, yet easy to read, providing a clear view to the lift arms and bucket link, ensuring safe operation in all site conditions.

REAR VISIBILITY



At the rear of the machines a contoured one-piece engine canopy drops away from the line of sight to give an excellent view behind the operator. The engine air pre-cleaner and exhaust stack are positioned in line in the centre of the canopy to further increase visibility over the back of the machine.

A large single rear screen, with pillars level with the operator, ensures an unbroken view to the rear three-quarters of the 721E and 821E. This is essential for a wheeled loader operator in a stocking and loading operation, and also for the XT machine in a materials handling situation.

A rear windscreen wiper is standard, ensuring that the view to the rear of the machine stays clear whatever the weather, minimising downtime and maximising productivity. Optional rear view camera systems can be fitted to both machines to further improve safety in mineral extraction operations.

OPERATOR'S CAB

Both the 721E and 821E feature a greatly enlarged operator's cab. The tapered cab design is both longer and wider than on the D Series machines, offering more internal space for the driver and noise levels that are among the quietest in the industry.

The full height door on the left hand side of the cab can be opened to 180 degrees, and locked in position, reducing any risk of damage. This provides excellent access to the cab for the operator.

On the right hand side of the machine the window can be opened slightly for increased air flow, or opened to 180 degrees and locked for maximum cross cab ventilation. Full cab air-conditioning is available as an option. There is plenty of storage in the cab, including a cool box when air conditioning is fitted.





The ergonomically designed Case wheel loaders can be specified with Ride Control, a system that allows the lift arms to float when the machine is moving, preventing bounce in the cab and at the wheels. Ride Control allows the operator to drive at higher speeds during load and carry operations, offering excellent load retention and reducing fatigue for the operator.

The system has three operating modes, fully on, off, to allow full hydraulic power during loading and digging operations, and an automatic setting, which engages Ride Control when the machine accelerates above 3mph.

The Ride Control system also reduces shock loadings in the chassis and in the operator's cab, prolonging component life and reducing operating costs for the owner and reducing fatigue and effort for the driver.



The 721E and 821E wheel loaders use a torque sensing autoshift transmission with four forward gears and three reverse ratios. The operator can opt for manual control of the transmission, or the gears can be shifted automatically as required. Forward and reverse shifting can be controlled using a shuttle switch in the head of the main hydraulic servo lever, allowing the operator to continue to work the attachment while changing direction.

Both axles feature limited slip differentials, to maximise traction and boost productivity. All four wheels are braked, using hydraulically-actuated maintenance-free wet disc brakes.

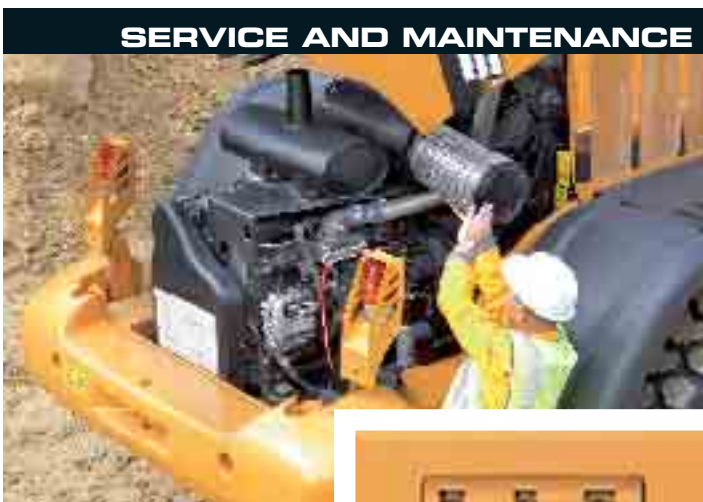

With the mid-mounted cooling module, the engine sits right at the rear of the machine, beneath a single-piece electrically-operated engine cover. The engine therefore contributes to the machine counterweight, reducing the need for additional counterweight at the rear.

This means that all daily checks can be easily reached from ground level, with fluid sight gauges on all reservoirs.

There are remote fluid drain taps for the engine oil, coolant and hydraulic oil, ensuring an environmentally-friendly service with no loss of fluids. Grease points are centrally located, to reduce downtime and increase productivity. All bucket pins have seals to protect against debris infiltration. This split seal is easy to replace, ensuring long pin and bush life.

Service personnel can access the machine diagnostic systems from within the cab using compatible electronic service tools.









SPECIFICATIONS

ENGINE

Model Case _____ Family IV 667TA/EED, Tier III certified
 Type _____ 6 cyl., turbocharged and air-to-air cooled
 Bore/Stroke _____ 104 X 132 mm
 Displacement _____ 6.7 L
 Fuel injection _____ Electronic
 Fuel filter _____ Replaceable, full flow spin-on cartridge
 Fuel cooler _____
 Air filter _____ Dry type element w/warning restriction indicator
 Mid-mount cooling module _____
 External independent mounted coolers _____
 Pump operating angle ratings _____
 Side-to-side _____ Rated 35°
 Fore and aft _____ Rated 35°
 Oil filtration _____ Replaceable, full flow spin-on cartridge
 Engine speeds - Rated speed, full load _____ 2000 rpm
 Horsepower - Peak _____
 Max Power _____
 Gross _____ 195 hp [145 kW] @ 2000 rpm
 Net _____ 183 hp [137 kW] @ 2000 rpm
 Standard Power _____
 Gross _____ 182 hp [136 kW] @ 1900 rpm
 Net _____ 172 hp [128 kW] @ 1800 rpm
 Economy Power _____
 Gross _____ 157 hp [117 kW] @ 1500 rpm
 Net _____ 149 hp [111 kW] @ 1500 rpm

NOTE: Gross horsepower and torque per SAE J1995.
 Net horsepower and torque per SAE J1349.

Torque - Peak _____
 Max Power _____
 Gross _____ 862 Nm@ 1400 rpm
 Net _____ 821 Nm@ 1400 rpm
 Standard Power _____
 Gross _____ 847 Nm@ 1400 rpm
 Net _____ 809 Nm@ 1300 rpm
 Economy Power _____
 Gross _____ 832 Nm@ 1200 rpm
 Net _____ 800 Nm@ 1200 rpm
 Torque rise _____
 Standard power @ 2000 rpm _____ 31.4%

DRIVETRAIN

Transmission _____
 4F/3R Proportional w/Electronic Control
 Module torque sensing autoshift/manual shift and modulation _____
 Differential _____ Limited slip on front and rear axles
 Rear axle oscillation _____ 24° total
 Service brakes _____
 Hydraulically actuated, maintenance-free, multiple wet disc with accumulator to all four wheels
 Parking brakes _____
 Spring-applied hydraulic release disc on transmission output shaft
 Travel speeds - km/h with 20.5x25 L3 Tires _____

	Forward	Reverse
1st	7.6	8.0
2nd	13.3	14.0
3rd	24.6	25.7
4th	38	NA

NOTE: Travel speeds at full engine throttle.

ELECTRICAL

Voltage _____ 24 Volts, negative ground
 Alternator _____ 65 amp
 Batteries _____ (2) 12-Volt

HYDRAULICS

Pump (steering/implement) _____
 Closed centered pressure/flow compensated _____
 Variable displacement _____ 119.6 L/min @ 2000 rpm @ 24 821 kPa
 Implement pump Closed centered pressure/flow compensated _____
 Variable displacement 85.6 L/min @ 2000 rpm @ 24 821 kPa
 Filtration _____
 10-micron, full flow replaceable cartridges on return line, condition indicator light for filter.

CYCLE TIME

Raise w/rated bucket load _____ 5.59 sec
 Dump w/rated bucket load _____
 Z-Bar _____ 1.8 sec
 XT _____ 1.9 sec
 Lower "empty" _____
 Power down _____ 3.29 sec
 Float down _____ 3.29 sec

SERVICE CAPACITIES

Fuel tank _____ 246 l
 Hydraulic system _____
 Total _____ 193.1 l
 Reservoir _____ 105.7 l
 Transmission _____
 Service with filter _____ 25.6 l
 Front and rear axle _____
 Front axle _____ 30.3 l
 Rear axle _____ 27.4 l
 Engine oil with filter _____ 14.2 l
 Cooling system (-40) _____ 36.9 l

OPERATING WEIGHTS

Z-Bar _____
 Unit equipped with ROPS cab with heater and A/C, full counterweight, 20.5R25 XTLA Michelin tires, 2.4 m³ bucket and quick coupler, full fuel, 79 kg operator _____ 14 500 kg

XT _____
 Unit equipped with ROPS cab with heater and A/C, full counterweight, 20.5R25 XTLA Michelin tires, standard batteries, full fuel, 79 kg operator: _____
 with 2.4 m³ bucket and quick coupler _____ 14 650 kg
 with pallet fork _____ 13 730 kg

GENERAL DIMENSIONS 721E

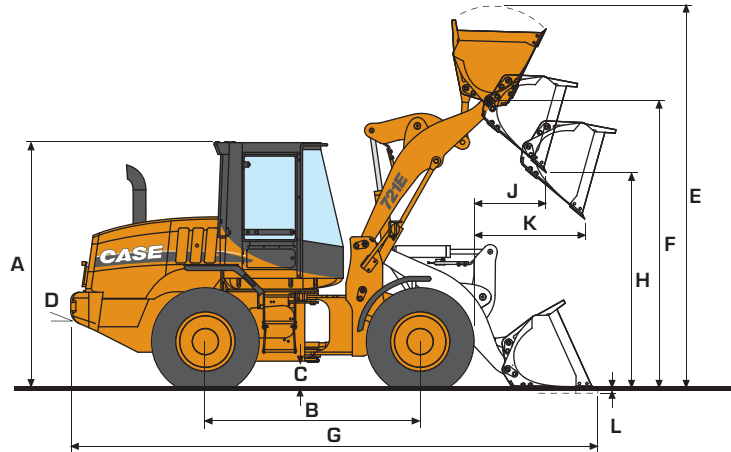

DIMENSIONS

A	Height to top of ROPS cab	mm	3404
B	Wheelbase	mm	3253
C	Ground clearance	mm	365
D	Angle of departure		32°
Width			
	- Overall* w/o bucket	mm	2500
	- Centerline tread	mm	2029
	Turning radius* - outside	mm	5750
Turning angle			
	- From center		40°
	- Total angle		80°
	Rear axle oscillation, total		24°

NOTE: *Dimensions taken with 20.5R25 Michelin XTLA tires.

WEIGHT ADJUSTMENTS Select Options

	Weight Adj. (kg)	Tipping Load Adj. Straight (kg)	Tipping Load Adj. 40° Turn (kg)
20.5 25 12 ply L2 tires	- 58	- 48	- 42
20.5 25 12 ply L3 tires	+103	+84	+74
20.5R 25 XHA TL tires	+172	+140	+124
Standard counterweight	-555	-1314	-1112

PERFORMANCE DATA

721E Z-Bar*

		Bucket with quick coupler					
		2.5 m ³ Bucket w/Bolt-on Edge	2.5 m ³ Bucket w/Teeth	2.7 m ³ Bucket w/Bolt-on Edge	2.7 m ³ Bucket w/Teeth	2.4 m ³ Bucket w/Bolt-on Edge	2.4 m ³ Bucket w/Teeth
SAE bucket capacity - heaped	m ³	2.50	2.50	2.70	2.70	2.40	2.40
Bucket width - outside	mm	2500	2500	2540	2540	2474	2474
Bucket weight	kg	1186	1273	1260	1347	1656	1619
E Operating height - fully raised w/spillguard	mm	5230	5230	5300	5300	5510	5510
F Hinge pin height - fully raised	mm	3980	3980	3980	3980	3980	3980
G Overall length - bucket level on ground	mm	7650	7800	7710	7860	7820	7940
Dump angle - fully raised		55°	55°	55°	55°	61°	61°
H Dump height - fully raised, 45° dump	mm	2930	2830	2890	2790	2820	2740
J Bucket reach - fully raised, 45° dump	mm	1130	1230	1170	1280	1270	1360
K Bucket reach - 2.13m height, 45° dump	mm	1660	1720	1690	1740	1760	1800
Operating load - ISO	kg	5460	5405	5430	5375	5455	5480
Maximum material density - ISO	kg/m ³	2196	2175	2029	2008	2273	2283
Tipping load - ISO							
- Straight	kg	12 590	12 480	12 530	12 420	12 630	12 680
- 40° turn	kg	10 920	10 810	10 860	10 750	10 910	10 960
Breakout force w/tilt cylinder	kg	14 260	14 180	13 520	12 050	12 200	11 300
Maximum rollback							
- Ground		39°	40°	39°	40°	34°	34°
- Carry position		43°	43°	43°	43°	38°	38°
- @ Maximum reach		54°	54°	54°	54°	49°	49°
- @ Full height		57°	57°	57°	57°	51°	51°
L Dig depth	mm	76	84	76	84	60	65
Maximum grading angle w/bucket - back dragging		60°	61°	60°	61°	67°	69°
Loader clearance circle	mm	12 640	12 760	12 680	12 800	12 600	12 680

NOTE: *Z-Bar performance data shown w/full counterweight. Performance data unit equipped with 20.5R25 Michelin XTLA tires, ROPS cab w/heater and A/C, full counterweight, standard batteries, front and rear fenders, full fuel and 75 kg operator. Specifications per SAE J732, J1234, J695, J742, and J818.

GENERAL DIMENSIONS 721EXT

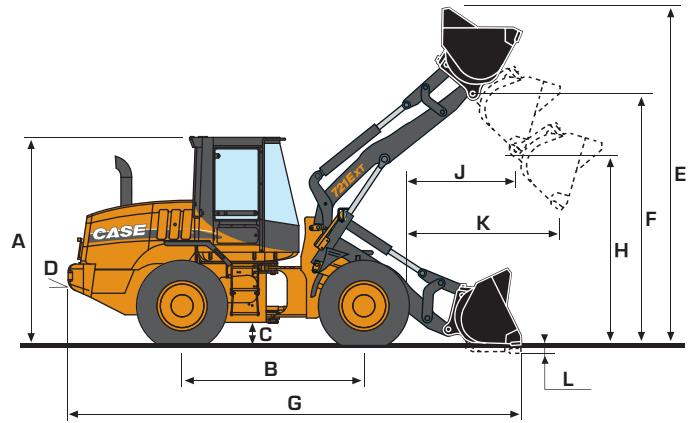
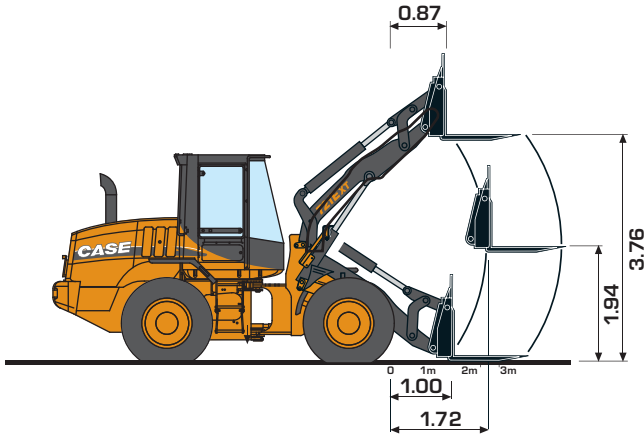

DIMENSIONS

A	Height to top of ROPS cab	mm	3404
B	Wheelbase	mm	3253
C	Ground clearance	mm	365
D	Angle of departure		32°
Width			
	- Overall* w/o bucket	mm	2550
	- Centerline tread	mm	2029
	Turning radius* - outside	mm	5750
Turning angle			
	- From center		40°
	- Total angle		80°
	Rear axle oscillation, total		24°

WEIGHT ADJUSTMENTS

Select Options	Weight Adj. (kg)	Tipping Load Adj. Straight (kg)	Tipping Load Adj. 40° Turn (kg)
20.5x25 12 ply L2 tires	-46	-37	-33
20.5x25 12 ply L3 tires	+103	+84	+74
20.5R25 XHA TL tires	+172	+140	+124
Standard counterweight	-555	-1314	-1112

721EXT WITH PALLET FORKS

Fork length	mm	1222
Fork weight (includes coupler)	kg	690
Tipping load - ISO		
- Straight	kg	8411
- 40° turn	kg	7101
Operating load - rough ground	kg	4261

NOTE: *Dimensions taken with 20.5R25 Michelin XTLA tires.

PERFORMANCE DATA

721E/XT

		Bucket with quick coupler	
		2.4 m ³ Bucket w/bolt-on edge	2.4 m ³ Bucket w/teeth
SAE bucket capacity - heaped	m ³	2.40	2.40
Bucket width - outside	mm	2474	2474
Bucket weight	kg	1630	1590
E Operating height - fully raised w/ spillguard	mm	5668	5668
F Hinge pin height - fully raised	mm	4161	4161
G Overall length - bucket level on ground	mm	8117	8236
Dump angle - fully raised		54°	54°
H Dump height - fully raised, 45° dump	mm	2769	2691
J Bucket reach - fully raised, 45° dump	mm	1272	1357
K Bucket reach - 2.13m height, 45° dump	mm	1748	1788
Operating load - ISO	kg	5622	5645
Maximum material density - ISO	kg/m ³	2343	2252
Tipping load - ISO			
- Straight	kg	13 000	13 047
- 40° turn	kg	11 243	11 290
Breakout force w/ tilt cylinder	kg	12 016	11 194
Maximum rollback			
- Ground		58°	58°
- Carry position		58°	58°
- @ Maximum reach		55°	55°
- @ Full height		59°	59°
L Dig depth	mm	206	211
Maximum grading angle w/ bucket - back dragging		61°	62°
Loader clearance circle	mm	12 491	12 544

NOTE: *Z-Bar performance data shown w/full counterweight. Performance data unit equipped with 20.5R25 Michelin XTLA tires, ROPS cab w/heater and A/C, full counterweight, standard batteries, front and rear fenders, full fuel and 75 kg operator. Specifications per SAE J732, J1234, J695, J742, and J818.

HYDRAULIC QUICK COUPLERS

The 721E can be specified with a heavy duty Z-bar linkage for high productivity digging and loading operations, or with an XT tool carrier linkage for materials handling duties. The 721EXT offers true parallel lift throughout the loading cycle, for maximum safety and efficiency when used with pallet forks and other materials handling attachments. To further increase the versatility and productivity of the 721EXT, the machine can be equipped with a hydraulic quick coupler. This enables the rapid changing of attachments from the driver's seat. The Case quick coupler is compatible with a wide range of materials handling attachments.



SPECIFICATIONS

ENGINE

Model _____ Case Family IV, 667TA/EBD Tier III Certified
 Type _____ 6 cyl., turbocharged and air-to-air cooled
 Bore/Stroke _____ 104 x 132 mm
 Displacement _____ 6.7 L
 Fuel injection _____ Electronic
 Fuel filter _____ Replaceable, full flow spin-on cartridge
 Fuel cooler _____
 Air filter _____ Dry type element w/warning restriction indicator
 Mid-mount cooling module _____
 External independant mounted coolers _____
 Pump operating angles _____
 Side-to-side _____ 35°
 Fore and aft _____ 35°
 Oil filtration _____ Replaceable, full flow, spin-on cartridge
 Engine speeds - Rated speed, full load _____ 2000 rpm
 Horsepower - Peak _____
 Max Power Range _____
 Gross _____ 227 hp (169 kW) @ 2000 rpm
 Net _____ 213 hp (159 kW) @ 2000 rpm
 Standard Power Range _____
 Gross _____ 210 hp (157 kW) @ 1800 rpm
 Net _____ 198 hp (148 kW) @ 1800 rpm
 Economy Power Range _____
 Gross _____ 190 hp (142 kW) @ 1500 rpm
 Net _____ 181 hp (135 kW) @ 1500 rpm

NOTE: Gross horsepower and torque per SAE J1995. Net horsepower and torque per SAE J1349.

Torque - Peak _____
 Max Power Range _____
 Gross _____ 1002 N·m @ 1400 rpm
 Net _____ 966 N·m @ 1400 rpm
 Standard Power Range _____
 Gross _____ 982 N·m @ 1400 rpm
 Net _____ 950 N·m @ 1300 rpm
 Economy Power Range _____
 Gross _____ 966 N·m @ 1200 rpm
 Net _____ 940 N·m @ 1200 rpm
 Torque rise _____
 Standard power @ 2000 rpm _____ 32.2%

DRIVETRAIN

Transmission _____
 4F/3R Proportional w/Electronic Control _____
 Module torque sensing autoshift/manual shift and modulation _____
 Differential Limited slip w/45% transfer on front and rear axles _____
 Rear axle oscillation _____ 24° total
 Service brakes _____
 Hydraulically actuated, maintenance-free, multiple wet disc w/accumulator to all four wheels _____
 Parking brakes _____
 Spring-applied hydraulic release disc on transmission output shaft _____
 Travel speeds - km/h with 23.5-25 L3 Tires _____

	Forward	Reverse
1st	7.1	7.9
2nd	12.6	13.8
3rd	23.3	25.3
4th	37.0	NA

NOTE: Travel speeds at full engine throttle.

ELECTRICAL

Voltage _____ 24 Volts, negative ground
 Alternator _____ 70 amp
 Batteries _____ 2 x 24 volt

HYDRAULICS

Pump (steering/implement) _____
 Closed centered pressure/flow compensated _____
 Variable displacement _ 119.6 L/min @ 2000 rpm @ 24 821 kPa
 Implement pump Closed centered pressure/flow compensated _____
 Variable displacement 120 L/min @ 2000 rpm @ 24 821 kPa
 Filtration _____
 10-micron, full flow replaceable cartridges on return line, condition indicator light for filter _____

CYCLE TIME

Raise w/rated bucket load _____ 5.6 sec
 Dump w/rated bucket load _____ 1.2 sec
 Lower _____ (empty)
 Power down _____ 2.8 sec
 Float down _____ 2.2 sec

SERVICE CAPACITIES

Fuel tank _____ 288 L
 Hydraulic system _____
 Total _____ 174 L
 Reservoir _____ 90 L
 Transmission _____
 Service w/filter _____ 39.7 L
 Front and rear axle _____
 Front _____ 37.4 L
 Rear _____ 23.7 L
 Engine oil w/filter _____ 21 L
 Cooling system _____ 40.9 L

OPERATING WEIGHTS

Z-Bar

Unit equipped with ROPS cab with heater and A/C, full counterweight, 23.5-25 XHATL Michelin tires, front and rear fenders, 2.70 m³ general purpose loader bucket, full fuel, 79 kg operator _____ 17 166 kg

GENERAL DIMENSIONS 821E

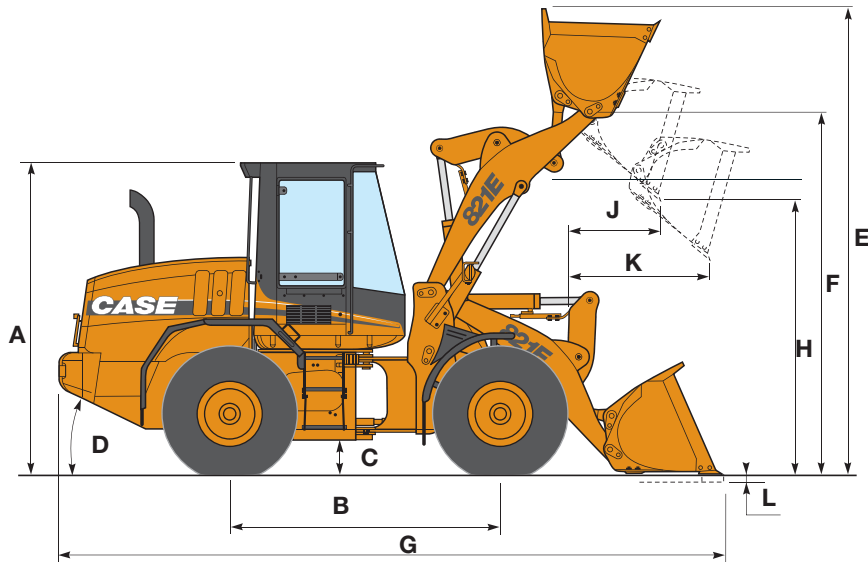

DIMENSIONS

A	Height to top of ROPS cab	mm	3450
B	Wheelbase	mm	3340
C	Ground clearance	mm	416
D	Angle of departure		33°
Width			
	- Overall* w/o bucket	mm	2890
	- Centerline tread	mm	2230
	Turning radius* - outside	mm	6032
Turning angle			
	- From center		40°
	- Total angle		80°
	Rear axle oscillation, total		24°

NOTE: *Dimensions taken with 23.5-25 XHATL tires.

WEIGHT ADJUSTMENTS

Select Options

Select Options	Weight Adj. (kg)	Tipping Load Adj. Straight (kg)	Tipping Load Adj. 40° Turn (kg)
Base counterweight	-680	-1637	-1381
L2BIAS tires	-506	-406	-358
L3BIAS tires	-218	-175	-154

NOTE: **Unit equipped with Z-Bar loader arms, 3.2 m³ general purpose pin on bucket w/ bolt-on edge, 23.5-25 XHATL tires, ROPS cab with heater/AC, full counterweight, heavy-duty batteries, front and rear fenders, full fuel and 79 kg operator. Adjust select options from rated weight.

PERFORMANCE DATA

821E Z-Bar

		3.4 m ³ Bucket w/Bolt-on Edge	3.2 m ³ Bucket w/Bolt-on Edge	3.2 m ³ Bucket w/Teeth	2.6 m ³ Bucket w/Bolt-on Edge	2.6 m ³ Bucket w/Teeth
SAE bucket capacity - heaped	m ³	3.39	3.17	3.17	2.63	2.63
Bucket width - outside	mm	2930	2930	3050	2930	3050
Bucket weight	kg	1591	1561	1615	1410	1463
E Operating height - fully raised w/ spillguard	mm	5530	5500	5500	5340	5340
F Hinge pin height - fully raised	mm	4120	4120	4120	4120	4120
G Overall length - bucket level on ground	mm	7890	7860	7990	7700	7830
Dump angle - fully raised		55°	55°	55°	55°	55°
H Dump height - fully raised, 45° dump	mm	2960	2980	2900	3090	3000
J Bucket reach - fully raised, 45° dump	mm	1130	1110	1210	980	1090
K Bucket reach - 2.13m height, 45° dump	mm	1720	1700	1760	1630	1690
Operating load - ISO	kg	6148	6202	6167	6320	6285
Maximum material density - ISO	kg/m ³	1814	1957	1946	2403	2390
Tipping load - ISO						
- Straight	kg	14 232	14 351	14 280	14 596	14 526
- 40° turn	kg	12 297	12 405	12 333	12 639	12 570
Breakout force w/ tilt cylinder	kg	15 611	16 061	14 505	18 479	16 480
Maximum rollback						
- Ground		41°	41°	41°	41°	41°
- Carry position		44°	44°	44°	44°	44°
- @ Maximum reach		54°	54°	54°	54°	54°
- @ Full height		59°	59°	59°	59°	59°
L Dig depth	mm	75	75	75	74	74
Maximum grading angle w/ bucket - back dragging		60°	60°	61°	59°	59°
Loader clearance circle	mm	13 206	13 186	13 374	13 100	13 280

NOTE: Performance data unit equipped with 23.5R25 XHATL tires, ROPS cab w/ heater and A/C, full counterweight, standard batteries, front and rear fenders, full fuel and 79 kg operator.

721E-EXT 821E

STANDARD EQUIPMENT & OPTIONS

STANDARD EQUIPMENT

Operator's environment

- ROPS cab with heat and A/C
- Articulated power steering with tilt column
- Fully adjustable, suspension seat
- 1-Lever loader control with wrist rest
- Cup holder
- Coat hook
- Storage tray behind seat
- Cooled lunch box
- Single brake pedal
- F/N/R shuttle switch
- External rear view mirrors
- Lock box
- Pressurized air filtering
- Defroster
- Side window, partial/fully open
- Dome light
- Wipers, rear and intermittent front
- Windshield washers, front and rear
- Secondary steering

Engine

- Case Family IV 667TA/EED
- Tier III certified
- Selectable work modes
 - Max power - Auto power
 - Standard power - Economy power
- Turbocharger
- Charge air cooling
- Automatic fan belt tensioner
- Integral engine oil cooling
- Fuel filter with water trap
- Dual element air cleaner
- 65 amp alternator

- (2) 700 CCA 12-volt batteries
- Liquid-cooled radiator
- Non spark-arresting muffler
- Mid-mounted cooling module
- Common rail electronic fuel injection
- Hydraulic reversing fan

Loader

- Z-bar loader linkage
- Single control for lift and tilt
- Positive hold float
- Automatic return-to-dig
- Automatic height control
- Automatic return-to-travel
- Brake pedal transmission disconnect

Drivetrain

- 4-wheel drive
- 4F/3R Selectable autoshift/manual shift transmission
- Electronic Control Module - Programmable, computer controlled proportional shifting with programmable gear selection
- Onboard diagnostics
- Single lever electronic shift control
- F/N/R switch in loader control handle
- Downshift button
- Torque converter
- Outboard planetary axles
- Limited-slip differentials
- Transmission oil cooler
- Brake pedal transmission disconnect
- Hydraulic wet disc brakes
- Spring-applied hydraulic release

- parking brake
- Limp-Home Mode
- Lubed-for-life drive shaft

Hydraulics

- Single lever 2-spool loader control valve
- Low-effort steering
- Hydraulic driven fan
- Diagnostic quick couplers
- Ride Control

Other

- Electric hood lift
- Front and rear fenders
- Lights
 - Front driving headlights (high/low beam)
 - Front flood
 - Stop/tail lights and backup light
 - Rear flood
- Front and rear turn signal/flash
- Standard counterweight
- Drawbar hitch
- Articulation locking bar
- Lift arm locking bar
- Lift and tie-down points - front/rear
- Backup alarm
- Remote drain points
- RH steps and platform

Engine

- Cold weather package
- Heavy-duty batteries

Loader

- Hydraulic attachment coupler
- Buckets

Hydraulics

- Auxiliary hydraulics
- 3 or 4-spool loader valves with 2 or 3-lever loader control

Tires

For 721E

- 20.5-25 12 PR L3 bias (rock)
- 20.5 R25 radial (dirt/traction)
- 20.5 R25 radial (rock)

For 821E

- 23.5 - 25 BIAS (rock)
- 23.5 R25 RADIAL (dirt/traction)
- 23.5 R25 RADIAL (rock)

Other

- Full coverage fenders
- Belly pan
- Tool box
- Full counterweight - Z-Bar

OPTIONS

Operator's compartment

- Radio
- Radio-ready (12 or 24-volt)
- Cab convenience package
- Rotating beacon

Standard and optional equipment shown can vary by country.

Worldwide Case Construction Equipment Contact Information

EUROPE/AFRICA/MIDDLE EAST:
Centre D'affaires EGB
5, Avenue Georges Bataille - BP 40401
60671 Le Plessis-belleville - FRANCE

NORTH AMERICA/MEXICO:
700 State Street
Racine, WI 53404 U.S.A.

LATIN AMERICA:
Av. General David Sarnoff 2237
32210 - 900 Contagem - MG
Belo Horizonte BRAZIL

ASIA PACIFIC:
Unit 1 - 1 Foundation Place - Prospect
New South Wales - 2148 AUSTRALIA

CHINA:
No. 29, Industrial Premises, No. 376,
De Bao Road, Waigaoqiao Ftz, Pudong,
SHANGHAI, 200131, P.R.C.

NOTE: Standard and optional fittings can vary according to the demands and specific regulations of each country. The illustrations may include optional rather than standard fittings - consult your Case dealer. Furthermore, CNH reserves the right to modify machine specifications without incurring any obligation relating to such changes.

Case Construction Equipment

CNH UK Ltd.
Armstrong House
The Finningley Estate
Hayfield Lane
Doncaster
DN9 3XA
Fax +44 (0)1302 802126

www.casece.com

CASE
CONSTRUCTION



Conforms to directive 98/37/CE